



SensComp, Inc.
36704 Commerce Rd.
Livonia, MI 48150
Telephone: (734) 953-4783
Fax: (734) 953-4518
www.senscomp.com

Analog Chip TL852

SensComp Electronic Component – TL852 Analog Integrated Circuit

Features

Economical Ranging Control when used with TL851 Digital IC
Operates With Single Supply Voltage.
Digitally Controlled Variable-Gain Variable-Bandwidth Amplifier.
Operational Frequency Range of 20 kHz to 90 kHz.
Overall Gain Adjustment with One External Resistor.
Interfaces to Electrostatic and Piezoelectric Transducers.
TTL Compatible.

Part No.

PID# 629409 – Analog IC TL852 – 16 pin SOIC (SMT) package
PID# 614906 – Analog IC TL852 – 16 pin N (thru-hole) package

Description

Specifications

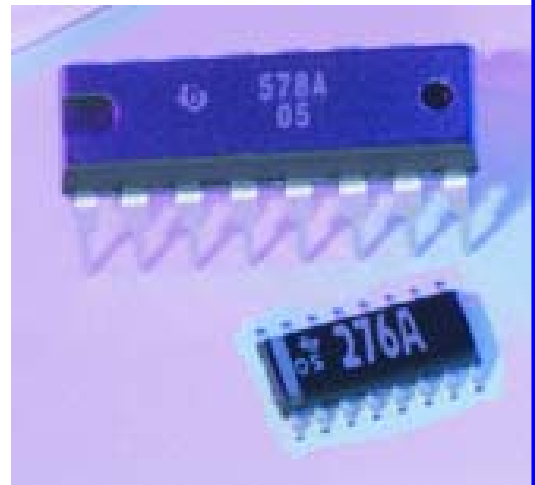

The TL852 is an economical sonar ranging receiver integrated circuit for use with the TL851 digital control integrated circuit. A minimum of external components is required for operation, and this amplifier easily interfaces to SensComp's 50-kHz electrostatic transducers.

An external resistor from BIAS (pin 8) to GND (pin 16) provides the internal biasing reference. The amplifier's gain can be set with a resistor from G1IN (pin 1) to GADJ (pin 3). Required amplifier gain will vary for different applications. A nominal peak-to-peak value of 230 mV input during gain step 2 is recommended for most applications. For reliable operation, a level no lower than 50 mV should be used. The recommended detect level of 230 mV can be obtained for most amplifiers with an R1 value between 5000 ohm and 20,000 ohm. Digital control of amplifier gain is provided with gain control inputs GCA, GCB, GCC, and GCD. These inputs must be driven synchronously (all inputs stable within 0.1 ms) to avoid false receive output signals due to invalid logic counts. This can be done easily with the TL851 control integrated circuit. To dampen ringing of the 50-kHz electrostatic transducer, a 5000 ohm resistor from G1IN to XIN is recommended.

An external parallel combination of inductance and capacitance between LC and V_{CC} provides an amplifier with an externally controlled gain and Q. This not only allows control of gain to compensate for attenuation of signal with distance, but also maximizes noise and sidelobe rejection. Care must be taken to accurately tune the LC combination at operating frequency or gain and Q will be greatly reduced at higher gain steps.

AC coupling between stages of the amplifier is accomplished with a 0.01 mf capacitor for proper biasing. The receive output is normally held at a low level by an internal 1 mA current source. When an input of sufficient amplitude is received, the output is driven alternately by the 1 mA discharge current and a 50 mA charging current. A 1000 pF capacitor is required from REC to GND to integrate the received signal so that one or two noise pulses will not be recognized.

XIN provides clamping for the transformer secondary when used for transducer transmit drive. The TL852 operates over a supply voltage of 4.5 volts to 6.8 volts (+5 volts DC nominal voltage) and is characterized for operation from 0°C to +40°C.

For more information, visit our website: www.senscomp.com

9/15/04

Absolute Maximum Ratings over Operating Free-Air Temperature Range

V _{CC} to ground (Pin 5 to16)	+7.0VDC
Voltage at any pin with respect to ground	-0.5 to +7.0 VDC
Voltage at any pin with respect to V _{CC}	-7.0 to +0.5 VDC
XIN (pin 2) input current (50% duty cycle).....	± 60 mA
Continuous power dissipation at (or below) 25° C free-air temperature (see note).....	1150 mW
Operating free-air temperature range.....	-40° C to 85° C
Storage temperature range	-65° C to 150° C
Lead temperature 1.6 mm (1/16 inch) from case for 10 seconds	260° C

Note: For operation above 25° C, derate linearly at the rate of 9.2 mW/C

Recommended Operating Conditions

		MIN	MAX	UNIT
Supply Voltage, V _{cc}		4.5	6.8	V
High-level Input Voltage, V _{IH}	GCA, GCB, GCC, GCD	2.1		V
Low-level Input Voltage, V _{IL}	GCA, GCB, GCC, GCD		0.6	V
Bias Resistor between BIAS and GND	(typical)	64.	72	KΩ
Operating Free-air Temperature	(recommended)	0	40	°C

Electrical Characteristics over Recommended Ranges of Supply Voltage (0 to 40° C)

PARAMETER		TEST CONDITIONS	MIN	TYP	MAX	UNIT
Continuous Operating Current					45	mA
High-level Input Current, I _{IH}	GCA, GCB, GCC, GCD	V _{IH} = 2V, V _{CC} = 5V		-0.5		μA
Low-level Input Current, I _{IL} ,	GCA, GCB, GCC, GCD	V _{IL} = 0, V _{CC} = 5V			-3	mA
Open Circuit Input Voltage	GCA, GCB, GCC, GCD	V _{CC} = 5V		2.5		V
Current through LC network					2.0	mA
Receive (REC) Output Current	No Signal Input	I _{G2IN} =-100 μA, V _O =0.3V		1		μA
	During Detect	I _{G2IN} =100 μA, V _O =0.1V		-50		μA
XIN Positive Clamp Voltage		I _{IN} = 40 mA			2.5	V
XIN Negative Clamp Voltage		I _{IN} = -40 mA		-1.3	-1.5	V

Pinout Description

Pin	Name	Description	Pin	Name	Description
1	G 1IN	Receiver Input	16	GND	Circuit Ground
2	XIN	Transducer Input	15	GCD	Gain Control D (MSB)
3	GADJ	Gain Adjustment	14	GCA	Gain Control A (LSB)
4	LC	Tuned Circuit	13	GCB	Gain Control B
5	V _{CC}	Positive Supply	12	GCC	Gain Control C
6	G1 OUT	First Gain Stage Output	11	n.c.	No internal connection
7	G2 IN	Second Gain Stage Input	10	n.c.	No internal connection
8	BIAS	Bias Resistor	9	REC	Detected Echo Output

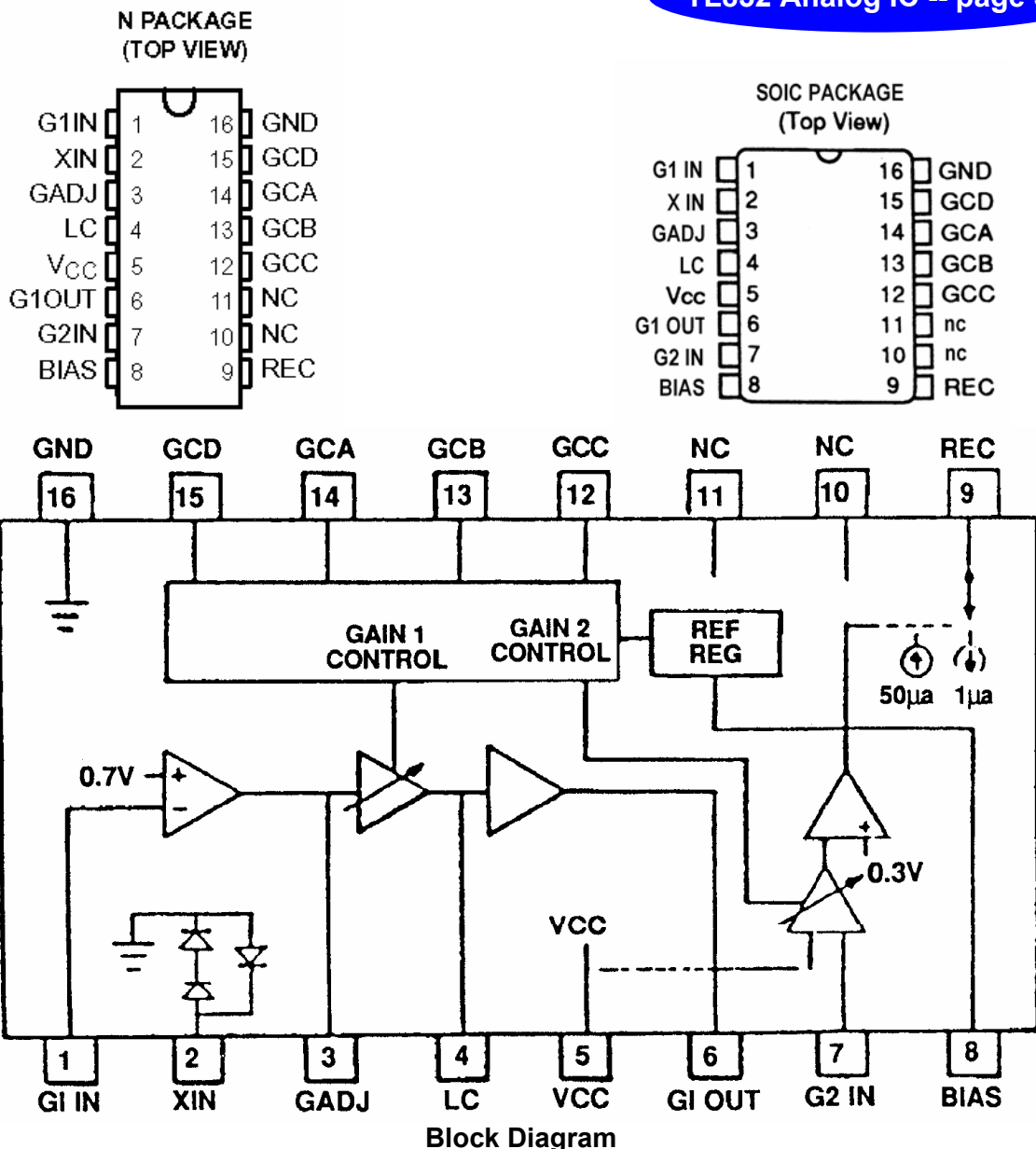

Detect Level vs Gain Step:

See test circuit on page 4. Detect level is measured by applying a 15 cycle burst of 49.4 kHz square waves just after the beginning of the gain step to be tested. The least burst amplitude which makes REC pin reach 1.2V is recorded as the "detect level". System "gain" is then inversely proportional to "detect level"

Step Number	GCA	GCB	GCC	GCD	Typical Relative Gain* (Peak to Peak)
0	0	0	0	0	
1	1	0	0	0	
2	0	1	0	0	
3	1	1	0	0	
4	0	0	1	0	
5	1	0	1	0	
6	0	1	1	0	
7	1	1	1	0	
8	0	0	0	1	
9	1	0	0	1	
10	0	1	0	1	
11	1	1	0	1	

*Assumes nominal external components and typical IC

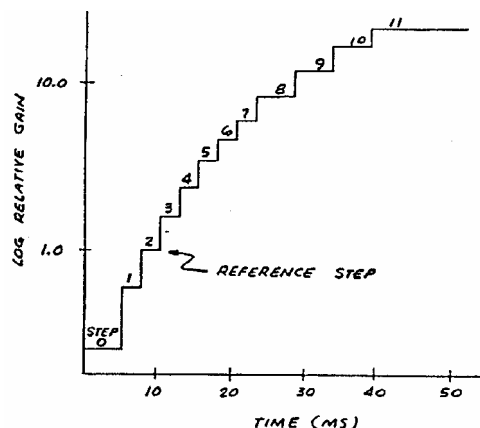

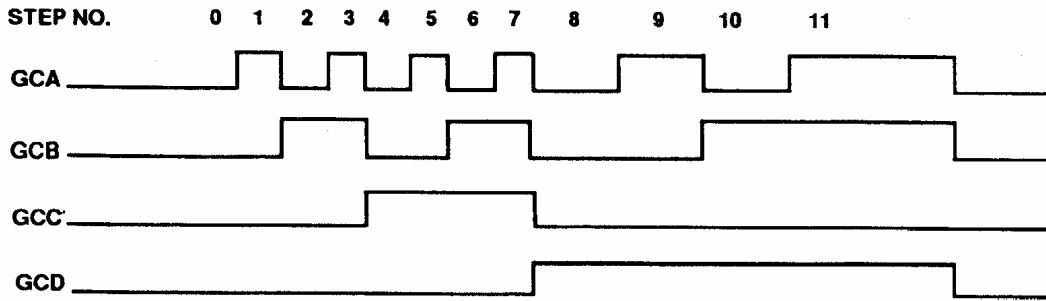
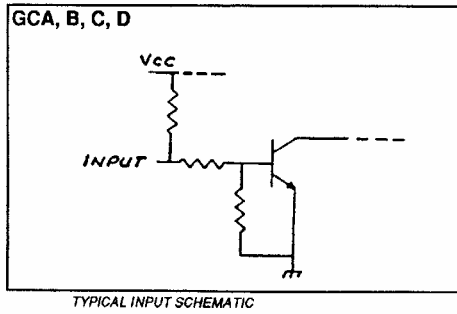

Typical Digital Gain Control Waveforms

Note: The counters providing the gain signals must be synchronous



Example of the REC Pin Response to 15 Cycle Burst
(test circuit)

NOTES:

1. ALL RESISTORS $\pm 1\%$, 1/4 WATT
2. ALL CAPACITORS $\pm 1\%$, FILM
3. L1 Q > 60 @ 50 kHz
4. C1 Q > 500 @ 50 kHz

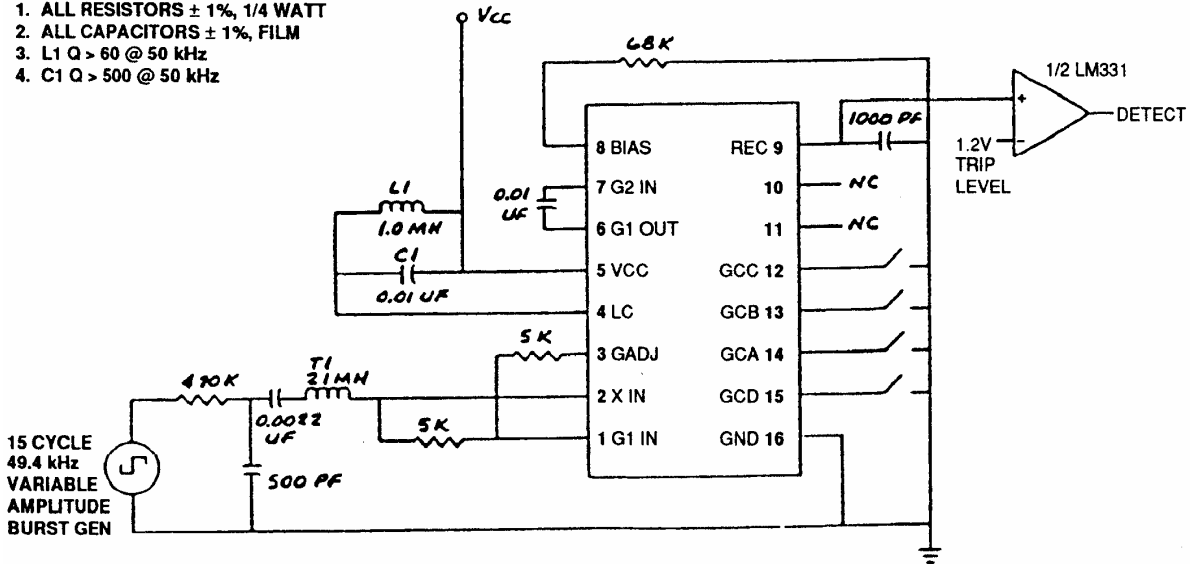

Direct Level Measurement Circuit